

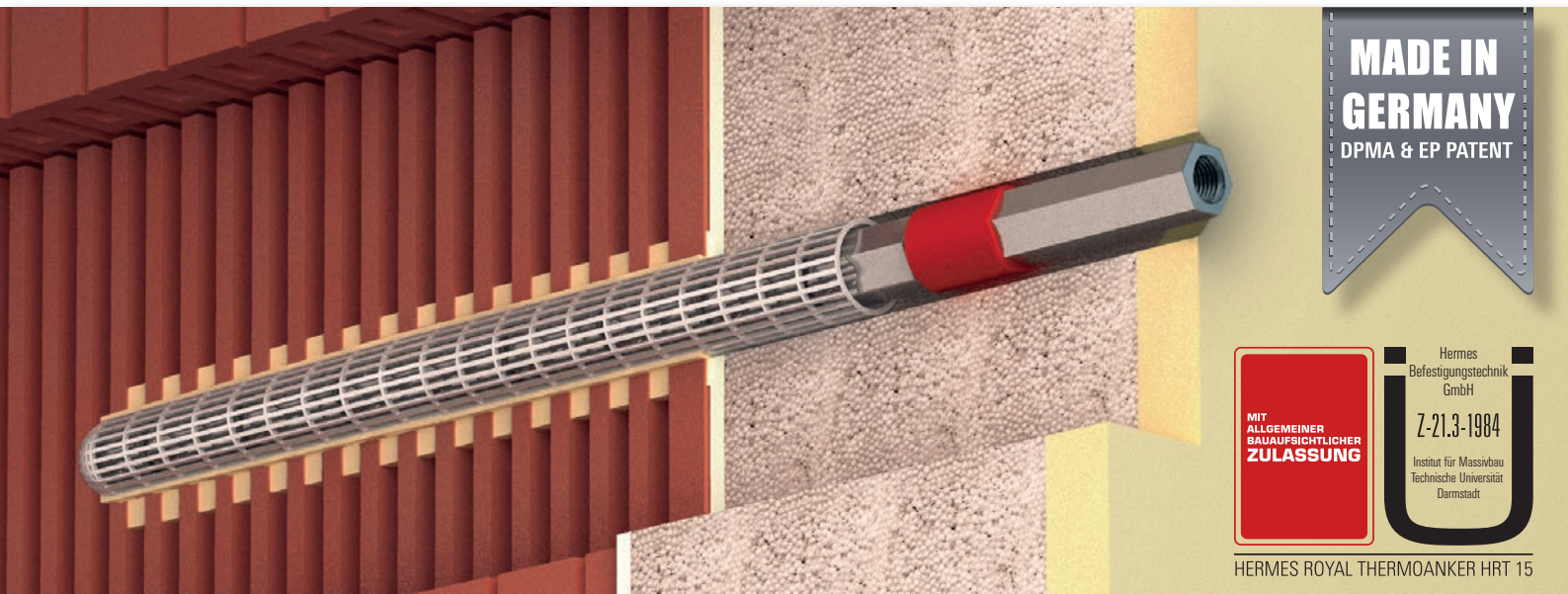

# HERMES ROYAL THERMO-ANKER

THE **NEW** INNOVATIVE ANCHORING METHOD FOR THERMALLY INSULATED EXTERIOR WALLS WITH A THERMAL INSULATION COMPOUND SYSTEM OF UP TO 25CM.



**MADE IN GERMANY**  
DPMA & EP PATENT



HERMES ROYAL THERMOANKER HRT 15

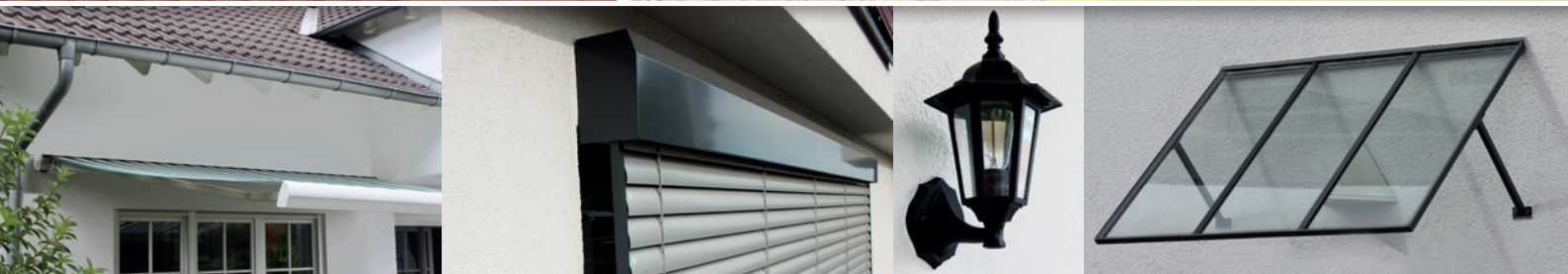

DPMA & EP PATENT

***NO HEAT LOSS DUE TO THERMAL BARRIER***

***NO THERMAL BRIDGES ON THE BUILDING***

***THERE IS NO NEED FOR CONSTRUCTIONAL PRELIMINARY WORK:  
E.G. THERMAL / ISO BLOCK, WOODEN SUBSTRUCTURES, BASE PLATES, ETC.***

***HIGH LOAD-BEARING CAPACITY – SUITABLE FOR UNIVERSAL USE***

***SIMPLE ASSEMBLY WITHOUT SPECIAL TOOLS***

***CAN BE USED ON THERMAL INSULATION COMPOUND SYSTEMS UP TO 25CM THICK***

***SAFETY GUARANTEED WITH BUILDING INSPECTORATE APPROVAL***

# Even in highly thermally insulated exterior walls the **HERMES ROYAL THERMO-ANKER** render thermal bridge effects negligible!

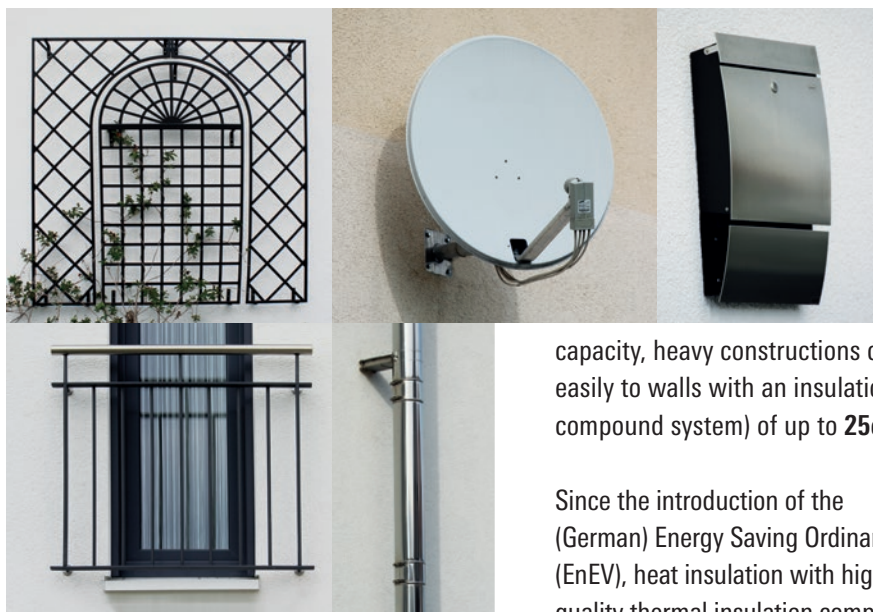

The **HERMES ROYAL THERMO-ANKER** is an anchoring system with a thermal barrier that allows heavy components weighing up to **40 kg (V<sub>zul</sub>)** per anchor to be mounted on thermally insulated exterior walls.

The **THERMO-ANKER** is an innovative and secure solution that prevents thermal bridging when mounting exterior components on thermally insulated exterior walls. Due to the high load capacity, heavy constructions can be attached simply, cost-efficiently and easily to walls with an insulation thickness (thermal insulation compound system) of up to **25cm**.

Since the introduction of the (German) Energy Saving Ordinance (EnEV), heat insulation with high quality thermal insulation compound

systems has been paramount in new buildings and in renovations. Planners and tradesmen are increasingly being faced with the task of mounting their constructions on these heat-insulated exterior facades. With a heat transition coefficient (**U value**) of **~0.2W/(m2.K)**, the Hermes Royal Thermo-Anker is the ideal system solution for thermally insulated walls.

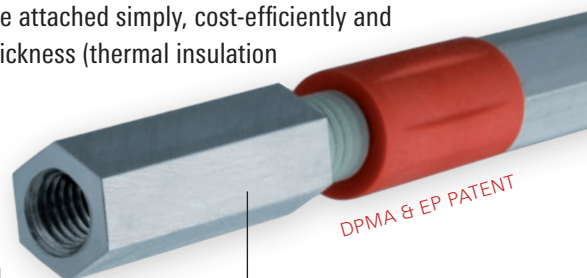

DPMA & EP PATENT

Stainless steel **holder** for fittings and mounting elements with metric threads

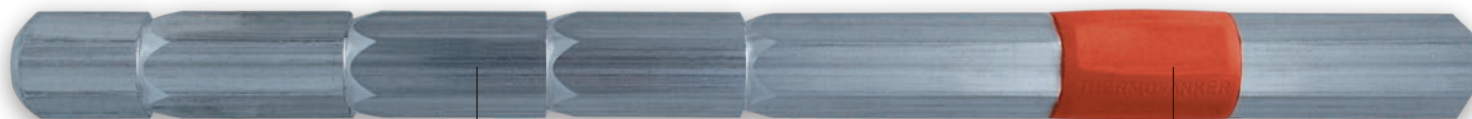

DPMA & EP PATENT

**Base frame** made of stainless steel or alvanized steel. Six-edged material with indents for a secure hold

**Thermal barrier** made of glass-fibre-reinforced plastic

The **HERMES ROYAL THERMO-ANKER** comes in two versions (heavy duty & light load) for an insulation thickness (thermal insulation compound system) of up to 25cm:

## HEAVY DUTY ANCHOR (HRT 15)

**Examples of use:** awnings, canopies, shutters, sliding shutters, balustrades, hand rails, blinds, French balconies, protection barriers, pergolas, conservatories, curtain walls, protruding shutter boxes, satellite dishes, etc.

## LIGHT LOAD ANCHOR (HRT 13)

**Examples of use:** outdoor lighting, post boxes, signs, house numbers, gutter pipes, external chimneys, alarm systems, window boxes, trellises, etc.

### HERMES ROYAL HEAVY DUTY ANCHOR (HRT 15)

The **HRT 15 stainless steel A4** is an approved component of the **Hilti HIT MM PLUS** (heed approval)

#### ART. NO. ARTICLE DESCRIPTION

1123132	Thermo-Anker 330 mm, SW15, anchor galvanised steel, holder stainless steel A4, thread M10
1123141*	Thermo-Anker 330 mm, SW15, anchor stainless steel A4, holder stainless steel A4, thread M10
1123152	Thermo-Anker 370 mm, SW15, anchor galvanised steel, holder stainless steel A4, thread M10
1123161*	Thermo-Anker 370 mm, SW15, anchor stainless steel A4, holder stainless steel A4, thread M10
1124132	Thermo-Anker 330 mm, SW15, anchor galvanised steel, holder stainless steel A4, thread M12
1124141*	Thermo-Anker 330 mm, SW15, anchor stainless steel A4, holder stainless steel A4, thread M12
1124152	Thermo-Anker 370 mm, SW15, anchor galvanised steel, holder stainless steel A4, thread M12
1124161*	Thermo-Anker 370 mm, SW15, anchor stainless steel A4, holder stainless steel A4, thread M12

### HERMES ROYAL LIGHT LOAD ANCHOR (HRT 13)

The **HRT 13** is not an approved component

#### ART. NO. ARTICLE DESCRIPTION

1111130	Thermo-Anker 330mm, SW13, anchor in galvanised steel, holder stainless steel A2, thread M6
1111150	Thermo-Anker 370mm, SW13, anchor in galvanised steel, holder stainless steel A2, thread M6
1112130	Thermo-Anker 330mm, SW13, anchor in galvanised steel, holder stainless steel A2, thread M8
1112150	Thermo-Anker 370mm, SW13, anchor in galvanised steel, holder stainless steel A2, thread M8
1113130	Thermo-Anker 330mm, SW13, anchor in galvanised steel, holder stainless steel A2, thread M10
1113150	Thermo-Anker 370mm, SW13, anchor in galvanised steel, holder stainless steel A2, thread M10

\*approved component

maximum approved tensile and shear loads and component dimensions for the HRT 15\*

		sustainability of thermal barrier		solid brick				perforated brick			
		Mz	KS	PB 2	PB 4	Hlz	KSL	Hbn	Bims		
perforated-/solid brick geometry		see approval (attachment 5)									
$c_{min}$ [mm]		50	50	150	150	35	35	35	70		
$s_{min}$ [mm]		100	100	300	300	70	70	70	140		
<b>tensile loads per dowel</b>											
$N_{Rk}$ [kN]	1,80	2,26	2,50	0,81	2,35	0,35	0,35	0,35	0,60		
$N_{Rd}$ [kN]	0,72	0,90	1,00	0,41	1,18	0,14	0,14	0,14	0,24		
$N_{zul}$ [kN] <sup>1)</sup>	0,51	0,64	0,71	0,29	0,84	0,10	0,10	0,10	0,17		
<b>shear loads per dowel (load to free border)</b>											
$V_{Rk}$ [kN]	1,40	7,85	7,67	1,14	3,30	0,30	1,00	1,00	0,40		
$V_{Rd}$ [kN]	0,56	3,14	3,06	0,57	1,65	0,12	0,40	0,40	0,12		
$V_{zul}$ [kN] <sup>1)</sup>	0,40	2,24	2,19	0,41	1,18	0,09	0,29	0,29	0,09		
<b>shear loads per dowel (load parallel or off to free border or <math>c &gt; 250</math> mm)</b>											
$V_{Rk}$ [kN]	1,40	7,85	7,67	1,14	3,30	0,60	2,00	2,00	0,80		
$V_{Rd}$ [kN]	0,56	3,14	3,06	0,57	1,65	0,24	0,80	0,80	0,32		
$V_{zul}$ [kN] <sup>1)</sup>	0,40	2,24	2,19	0,41	1,18	0,17	0,57	0,57	0,23		

1) mit  $\gamma_f = 1,4$

lever arm		solid brick				perforated brick			
shear loads with lever arm per dowel (Belastung parallel oder weg vom freien Rand oder $c \geq 250$ mm)									
$\delta_{v0} = 5,0$ mm		Mz	KS	PB 2	PB 4	Hlz	KSL	Hbn	Bims
$V_{max,zul}$ [kN] für $\delta_{v0}$	30 mm	0,40	0,40	0,40	0,40	0,17	0,40	0,40	0,23
$V_{max,zul}$ [kN] für $\delta_{v0}$	bis	0,40	0,40	0,40	0,40	0,17	0,40	0,40	0,23
$V_{max,zul}$ [kN] für $\delta_{v0}$	100mm	0,40	0,40	0,40	0,40	0,17	0,40	0,40	0,23
$V_{max,zul}$ [kN] für $\delta_{v0}$	120 mm	0,40	0,40	0,40	0,40	0,17	0,40	0,40	0,23
$V_{max,zul}$ [kN] für $\delta_{v0}$	140 mm	0,40	0,40	0,40	0,40	0,17	0,40	0,40	0,23
$V_{max,zul}$ [kN] für $\delta_{v0}$	160 mm	0,40	0,40	0,40	0,40	0,17	0,40	0,40	0,23
$V_{max,zul}$ [kN] für $\delta_{v0}$	180 mm	0,28	0,28	0,28	0,28	0,17	0,28	0,28	0,23
$V_{max,zul}$ [kN] für $\delta_{v0}$	200 mm	0,20	0,20	0,20	0,20	0,17	0,20	0,20	0,20
$V_{max,zul}$ [kN] für $\delta_{v0}$	250 mm	0,10	0,10	0,10	0,10	0,10	0,10	0,10	0,10

\* meanderings attend in approval

**HILTI ACCESSORIES AND SUPPLIES FOR WORKING WITH HERMES ROYAL THERMO-ANKER HRT 15 AND HRT 13:**

**SET – HRT 15 OR HRT 13**

Inkl. Injektionsmörtel  
Hilti HIT-MM PLUS 330/2



**SET – HRT 13**

Inkl. grout injection mortar Hilti HFX 275/2



**BASIC SET – HRT 15 OR HRT 13**

Thermo-Anker HRT 15 or HRT 13, incl. grout injection mortar Hilti HIT-MM PLUS 330/2 and dispenser Hilti HDM 330 CR/CB in the box



**BASIC SET – HRT 13**

Thermo-Anker HRT 13 incl. grout injection mortar Hilti HFX 275/2 and dispenser Hilti MD 1000 in the box



**PREMIUM SET – HRT 15 OR HRT 13**

Inkl. grout injection mortar Hilti HIT-MM PLUS 330/2, dispenser Hilti HDM 330 CR/CB in the case + drill, steel brush and blow-out pump



**PREMIUM SET – HRT 13**

Inkl. grout injection mortar Hilti HFX 275/2 and dispenser Hilti MD 1000 in the box + drill, steel brush and blow-out pump



# ASSEMBLY/SET INSTRUCTIONS

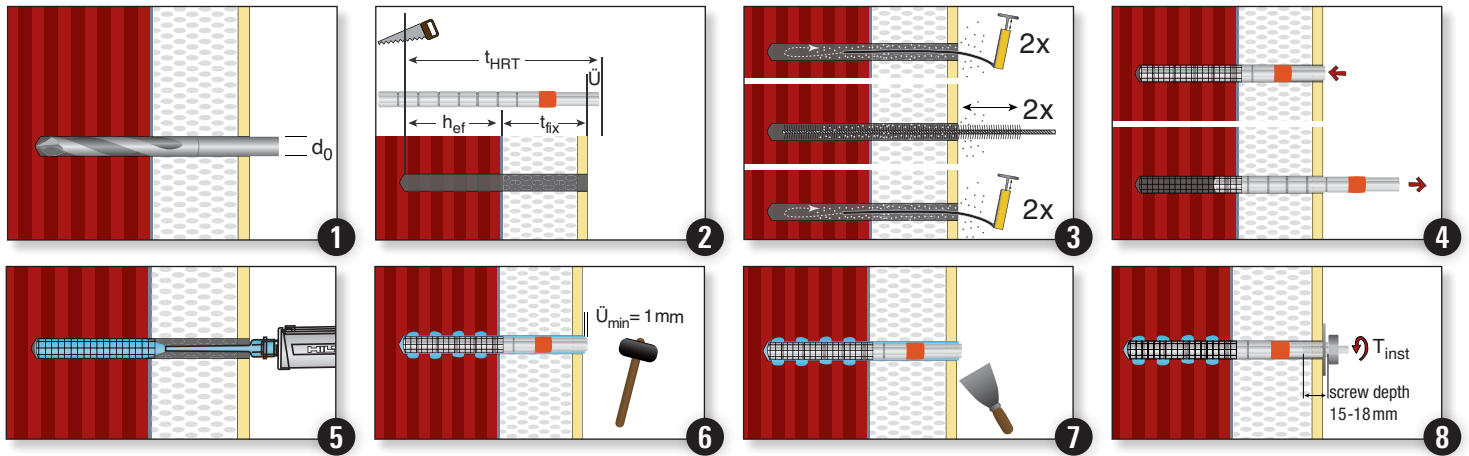

1. Drill hole: HRT 15 »  $d_0 = 20\text{mm}$  / HRT 13 »  $d_0 = 18\text{mm}$
2. Thermo-Anker/Cut sleeve to appropriate length as necessary
3. Clean drill hole: 2x blowing, 2x brushing, 2x blowing
4. Insert sleeve into the wall using the Thermo-Anker – pull the Thermo-Anker out again – the sleeve remains in the wall
5. Inject **Hilti HIT-MM PLUS** into the sleeve completely until it comes out of the mouth of bore (Observe Hilti instruction manual!)
6. Hammer/screw in the Thermo-Anker until it protrudes at least 1mm over the final layer of plaster
7. Level any surplus Hilti HIT on the outer wall out with a trowel for sealing purposes, remove surplus and leave to set
8. Secure attachment while observing torque  $T_{inst}$

Because installing a **HERMES ROYAL THERMO-ANKER** requires no additional components or preliminary installations, assembly is more cost-efficient and just as effective as systems to date. The **HERMES ROYAL THERMO-ANKER** should ideally be positioned once the insulation (thermal insulation compound system) and the mesh filter have been installed and before the final layer of plaster has been applied. It can, however, also be installed at a later stage.

## ASSEMBLY DATA

Type	Thickness of Anchor	Material**	Min. anchor depth $h_{ef}$	Min. drill hole depth $h_d$	Drill hole diameter $d_0$	length of Thermo-Anker $t_{HRT}$	length of sleeves	Req. min. quantity of mortal (approx. Info.)		Screw depth of threaded holder		$T_{inst. max}$
								8 Hub	40ml	Min	Max	
HRT 15	SW 15	Concrete/Solid Brick	100mm	$h_d = h_{ef} + 10\text{mm}$	20mm	$t_{HRT} = t_{fix} + h_{ef} + \ddot{U}$	$t_{HRT} - 80\text{mm}$	8 Hub	40ml	15mm	18mm	5Nm
		Perforated brick	150mm		20mm			18 Hub	90ml	15mm	18mm	2Nm
HRT 13*	SW 13	Concrete/Solid Brick	100mm	$h_d = h_{ef} + 10\text{mm}$	18mm	$t_{HRT} = t_{fix} + h_{ef} + \ddot{U}$	$t_{HRT} - 75\text{mm}$	7 Hub	35ml	15mm	18mm	5Nm
		Perforated brick	150mm		18mm			17 Hub	85ml	15mm	18mm	2Nm

\* no element in approval

\*\* concrete is no element in approval. Attend approval.

## Diagram

Cross-section of wall with full heat insulation  
Installation point for surface/straight assembly of Thermo-Anker.

The innovative construction of the **THERMO-ANKER** allows for trouble-free straight or inclined installation/corner installation close to the intrados edge.

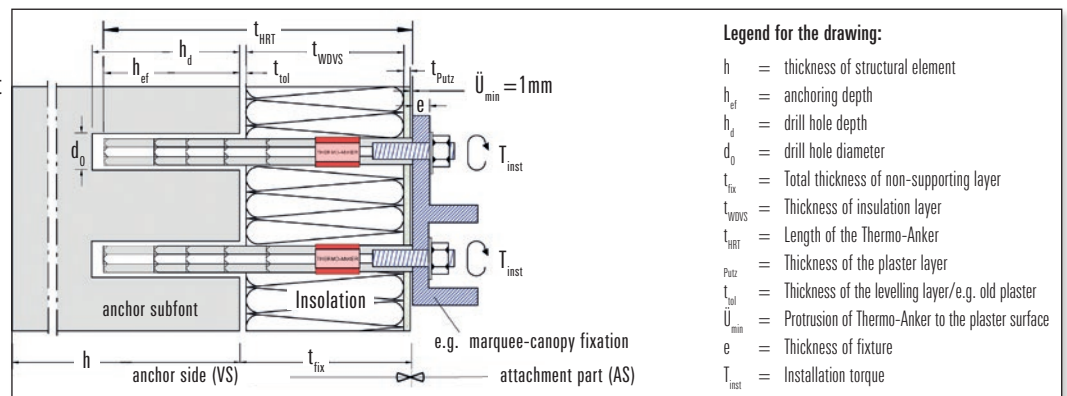

### Legend for the drawing:

- $h$  = thickness of structural element
- $h_{ef}$  = anchoring depth
- $h_d$  = drill hole depth
- $d_0$  = drill hole diameter
- $t_{fix}$  = Total thickness of non-supporting layer
- $t_{WDVS}$  = Thickness of insulation layer
- $t_{HRT}$  = Length of the Thermo-Anker
- $t_{Putz}$  = Thickness of the plaster layer
- $t_{tol}$  = Thickness of the levelling layer/e.g. old plaster
- $\ddot{U}_{min}$  = Protrusion of Thermo-Anker to the plaster surface
- $e$  = Thickness of fixture
- $T_{inst}$  = Installation torque